

# MARTIN® MXX Series Explosion-Proof Shale Shaker Vibrators

For more than 60 years people have counted on Martin Engineering to provide vibratory solutions.



## BENEFITS

- Higher Force to Weight Ratios with Comparable Bearing Life
- Unsurpassed 3-Year Warranty
- Local Manufacturing (Central Illinois)
- World-Wide Tech Support and Service
- Rated for Oil-Field Duty
- Thermostat or Thermistor Overload Circuit Not Required
- Any Electrical Rating Available
- Fixed or Fully Adjustable Eccentric Weights
- **Low or No Maintenance**  
Greasable or maintenance-free options

## AVAILABLE OPTIONS

- Self-Adjusting Swing Weights
- Stainless Steel and Spun Steel Weight Covers
- Maintenance-Free Units
- Custom Designs to Fit Your Needs



\* Excludes Bearings & Grease

# TECHNICAL DATA SHEET

## Dimensions—in. (mm)

Model	A	B	C	D	E	F	#	G	H	M
MMX18-7200	23.31 (592)	12.20 (310)	10.63 (270)	6.10 (155)	8.86 (225)	1.17 (30)	4	0.87 (22)	5.31 (135)	9.53 (242)
MIX18-7200	23.31 (592)	12.20 (310)	10.63 (270)	3.15 (80)	8.27 (210)	1.17 (30)	6	0.67 (17)	5.31 (135)	9.53 (242)
MVX18-7200	23.31 (592)	12.20 (310)	10.63 (270)	3.27 (83)	9.02 (229)	1.17 (30)	6	0.87 (22)	5.31 (135)	9.53 (242)
MMX18-9750	24.72 (628)	13.50 (343)	12.40 (315)	6.10 (155)	10.04 (255)	1.14 (29)	4	0.93 (24)	6.10 (155)	10.43 (265)
MIX18-9750	24.72 (628)	13.50 (343)	12.40 (315)	3.35 (85)	10.63 (270)	1.14 (29)	6	1.02 (26)	6.10 (155)	10.43 (265)
MVX18-9750	24.72 (628)	13.50 (343)	12.40 (315)	4.13 (105)	9.76 (248)	1.14 (29)	6	0.87 (22)	6.10 (155)	10.43 (265)

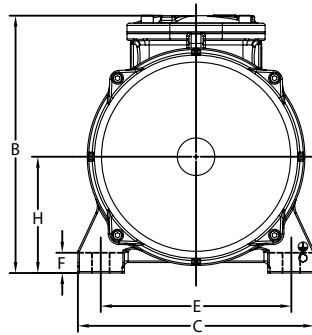
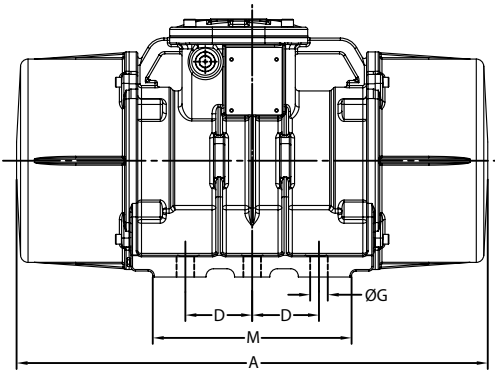

## Specifications

Model	Power (HP)	Force (lbs)	Amps 230/460V	Weight (lbs)	Frame Size
MXX18-7200	2	7230	5.8/2.9	230	60
MXX18-9750	2.5	9812	7.4/3.7	290	70